

PEC Code: 5330-115 COM Code: 408184034 Model: LURCVCS	Voice Coil Speaker
PEC Code: 5330-215 COM Code: 408184059 Model: LURC70VS	70V Speaker
PEC Code: 5335-030 COM Code: 408184562 Model: LURCSE	Backbox

Round Voice Coil or 70V Speaker with Support Bridge

Speaker Installation

- 1 Unscrew, cut off, or break (plastic) shipping screws that mount the speaker to the bridge support. Discard any packing material.
- 2 Remove ceiling tile from ceiling and place on floor or over large trash can (provides support and saves clean up time). Place the ceiling tile with the finished position side facing up.

- 3 Using the bridge support as a template, mark an 8-1/2" square opening in the ceiling tile as shown in the illustration. Remove the bridge support and cut out the square with a utility knife.

- 4 Turn ceiling tile over so the unfinished side is facing up. Replace bridge support over cutout. Bend tabs (8) into cutout to prevent sliding.

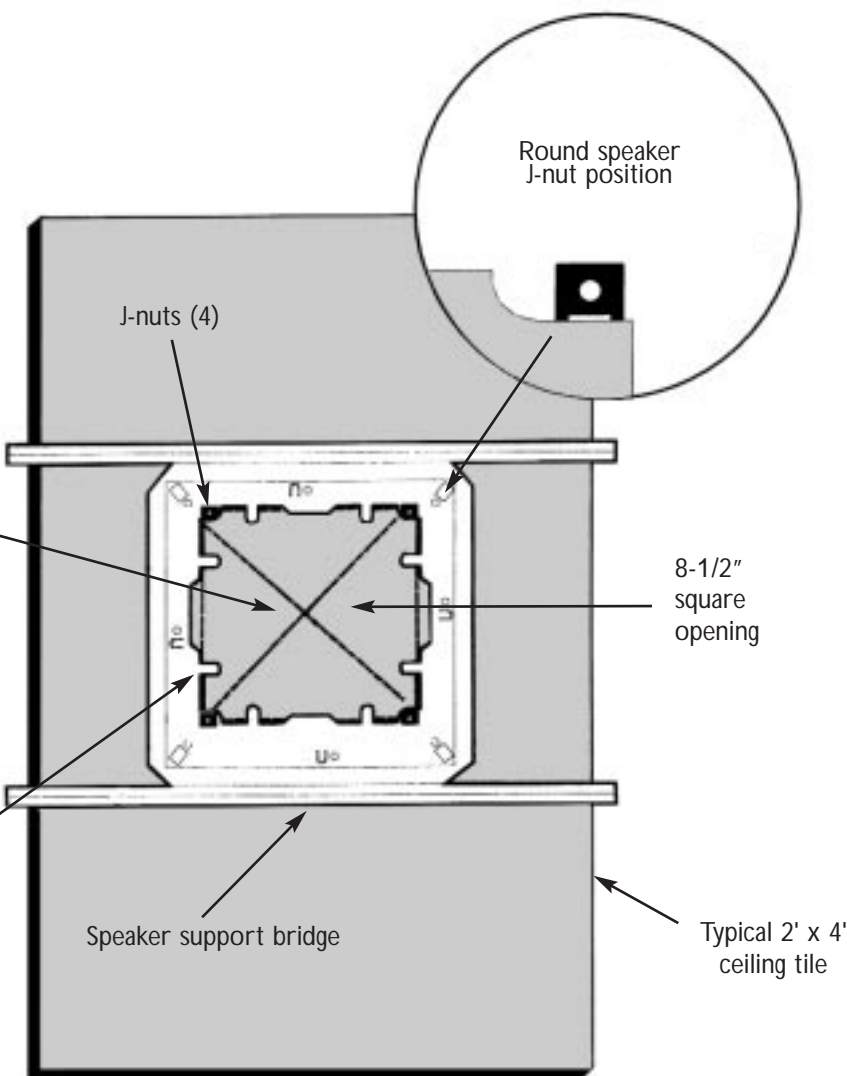

Backbox Installation

- 5** **Note:** This step covers the backbox (optional) installation. Skip this step and proceed to step 6 if you are not installing a backbox.

Punch out the knock-out in the backbox, and feed speaker wire through hole. Position the backbox onto the bridge support as shown and use horseshoe tabs to secure it into place.

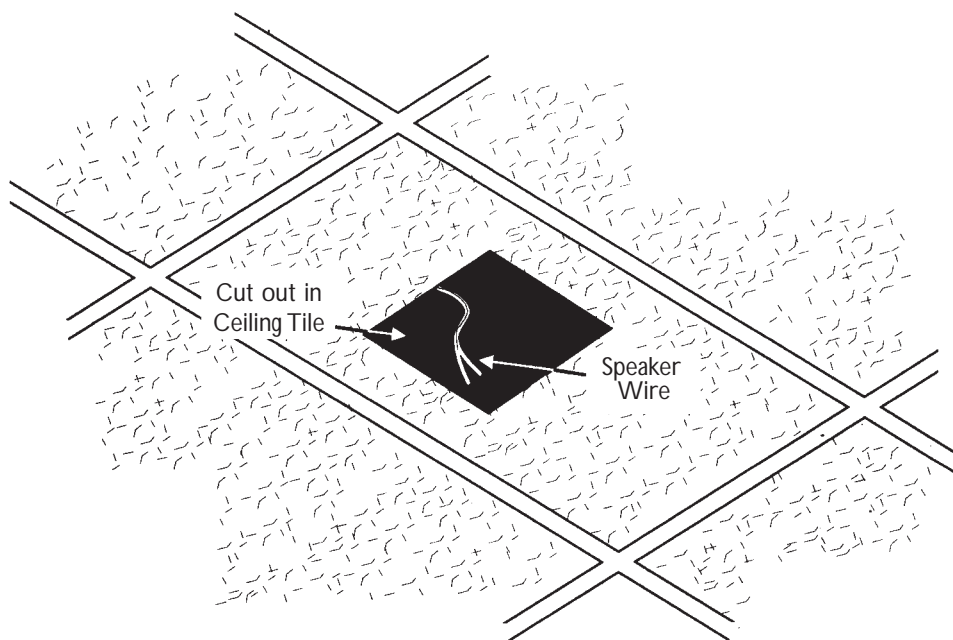
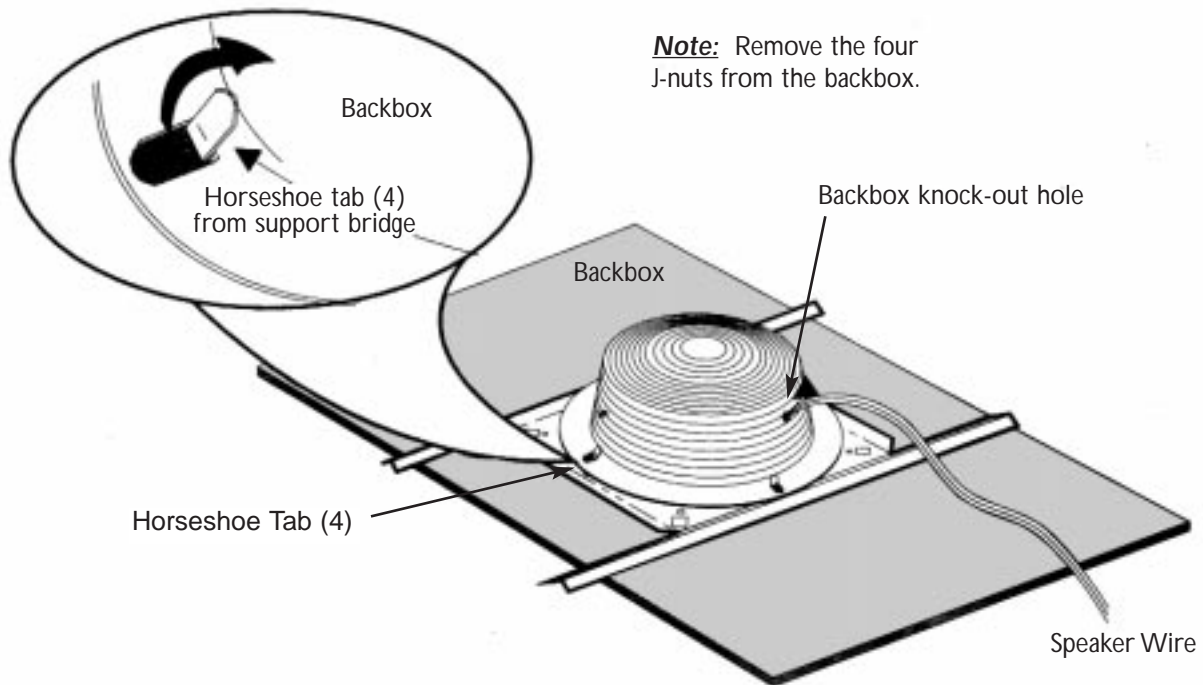

- 6** Place the ceiling tile (with attached speaker support bridge) back into its ceiling position. Ensure speaker wires are pulled to tile location.

7 The next step is to attach the speaker wires to the appropriate tap terminals located on the back of the speaker. **Note:** Use 22 AWG shielded, twisted pair on all wire runs. Com Code: 401882956. Pec Code: 2734-SPK. Connect speaker wire shield to the ground (GND) terminal of the amplifier's output. Carry the ground through all speaker cables by tying the shields of the speaker cables together in a "daisy chain" fashion. **Do not connect the shield to the speaker itself.** The shield is only connected at the amplifier end and simply floats.

Note: The speaker will also work perfectly well with these connections reversed. However, reduced low frequency response may result.

Use the appropriate instructions below (7a for voice coil speakers, or 7b for 70V round speakers).

7a Voice Coil Speaker

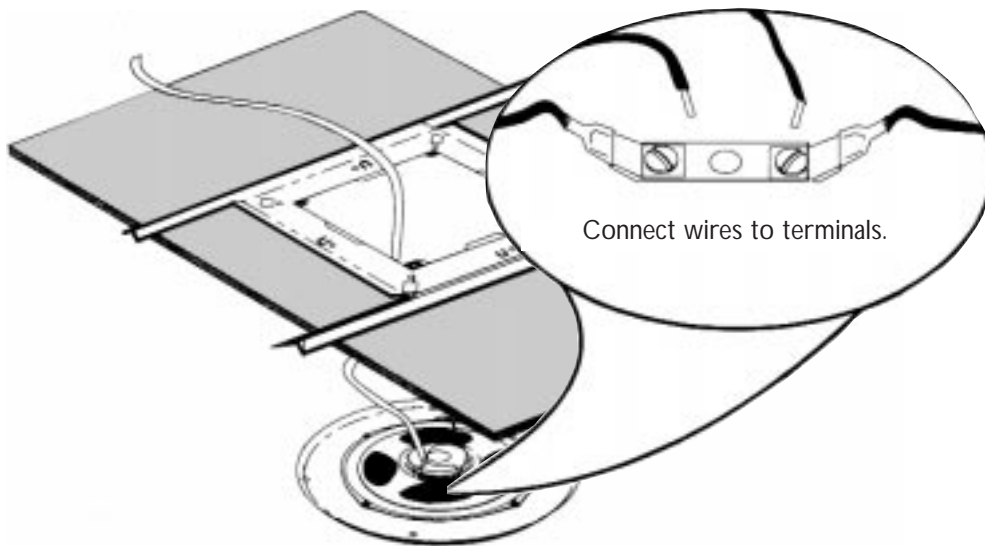

7b 70V Round Speakers

Note: With 70V speakers, select the lowest tap setting (1/8 W or 1/4 W) before testing the speakers. This ensures that nobody will be "blasted" when a page is made for the first time.

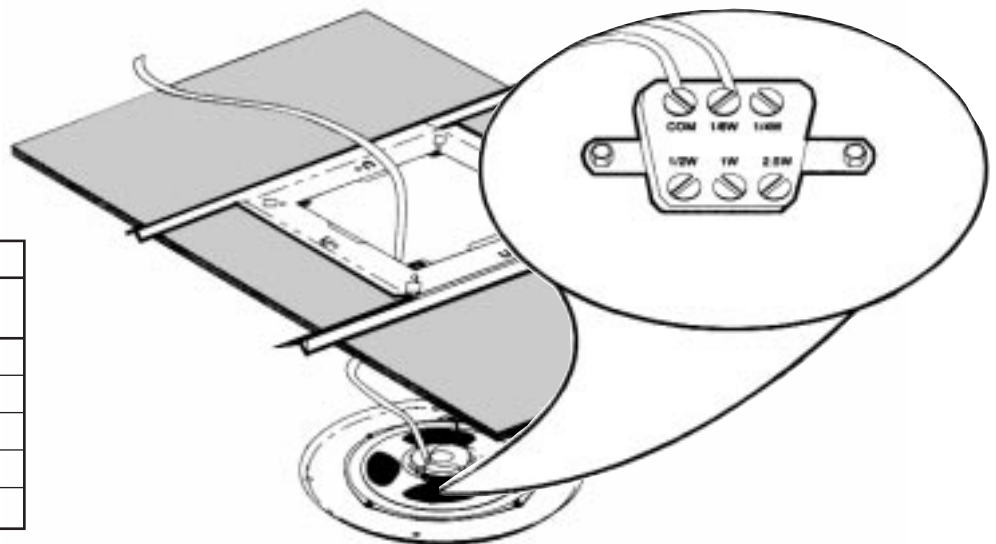

Tap Settings (70V Systems)		
Common Wire to:	Signal Wire to:	dB Out
Com	1/8 W	86
Com	1/4 W	89
Com	1/2 W	92
Com	1 W	95
Com	2.5 W	98

- 8 Mount the speaker assembly to the bottom surface of the ceiling tile. Secure with four mounting screws and J-nuts as illustrated.

Mounting Round Speaker Assembly

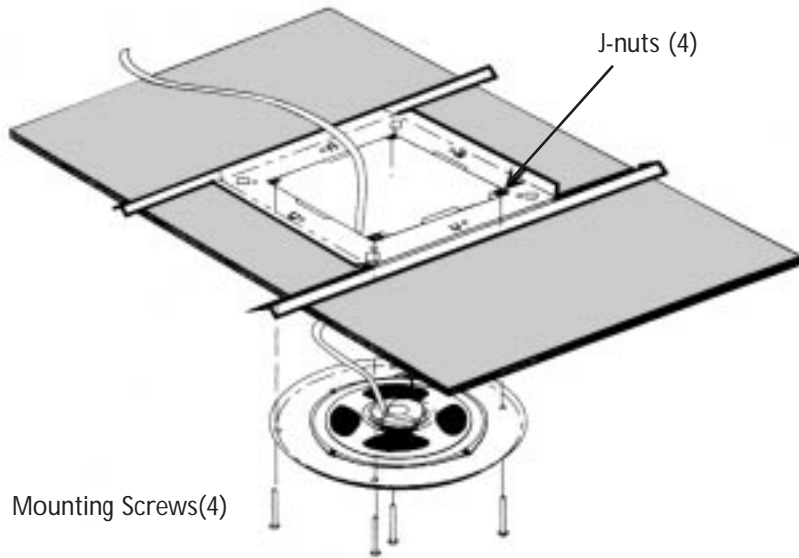

Note: If a backbox has been installed, speaker assemblies still mount as shown.

- 9 Use a screwdriver to turn the attenuator (located in the center of the speaker grille) to the fully clockwise position. Make a test page and adjust the attenuator and tap settings as follows:

- a) If page is too loud, turn the attenuator counterclockwise until desired level is attained.
- b) If page is not loud enough, move the signal wire to the next higher tap setting and retest. Continue until the appropriate tap setting is reached and use the attenuator to make fine adjustments.

Note: Final testing and adjustments should always be made at normal building sound levels.